

Generator set

Sound-proof type

PL1100PL

SPECIFICATIONS

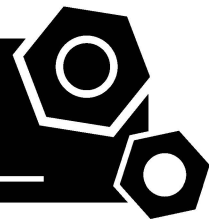

EP series PL1100PL

50 Hz @ 1500rpm, 3-Phase/4-wiring



1 Standards & Conditions

Design Standards

The designs and the productions are in conformity with:

- Conformance Européenne (CE)
- ISO8528-5:2005
- AS 3000-2018
- AS 3010-2017

Environmental Operating Conditions

- Installation place: Outdoors or indoors (well ventilated).
- Ambient temperature: -25°C to 50°C. The coolant heater is needed when the temperature is below 5°C
- Humidity: Less than 80%.
- Altitude: Below one thousand (1000) meters above sea Level.

Factory Inspection

- Inspection items.
- Protection devices working test.
- Starting ability in normal temperature.
- 50% rated power load moment capability.
- Voltage deviation and speed variation: 0%, 25%, 50%, 75%, 100%, 110% Load.

Painting Process

- Painting process specifications and colors are based on the manufacturer's standard.
- The customer could also choose the color which the manufacturer offers.

2 General Features

- Perkins engine 4008TAG2
- Close coupled to LSA alternator LSA49.3L10
- Microprocessor control module PLC-7420
- ABB main circuit breaker: 1600A
- Rotate speed governor: Electronic governor
- Excitation system: AREP
- A.V.R.Model: D350
- Key switch
- Emergency stop switch
- ATS (automatic transfer switch) receptacle
- 2x12V/150AH sealed for life maintenance free battery
- Lockable battery isolator switch

- Lockable battery isolator switch
- Powder coated canopy
- Standard container
- 50°C remote radiator
- Fire extinguisher
- Oil pump on the engine
- Vibration isolators between the engine/alternator and base frame
- Dry type air filter
- Fuel tank with 5 hours running
- Drain points for fuel tank
- Fuel-water separator for fuel tank
- Operation Manual / Specification

3 Equipment Specification

General technical data

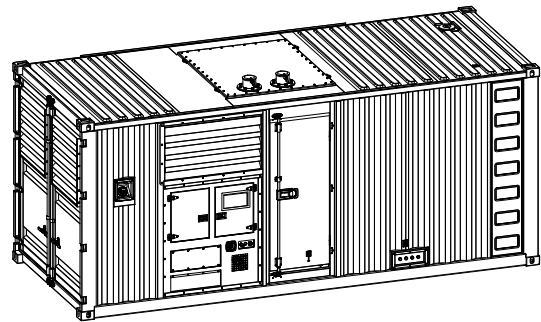

Model.....PL1100PL
 Structure typeC
 Tank capacity.....1150L
 Dry weight.....11570kg
 Noise level @7m79.6dBA
 Dimensions L×W×H.....6058x2438x2725mm
 Standby Power1100kVA/880kW
 Prime Power1000kVA/800kW

Voltage	380V	400V	415V	440V	
Ampere	1519A	1443A	1391A	1312A	
Genset Fuel Consumption					
Frequency/Load	25%	50%	75%	100%	110%
50Hz (L/h)	N/A	111	162	215	240

Diesel Engine

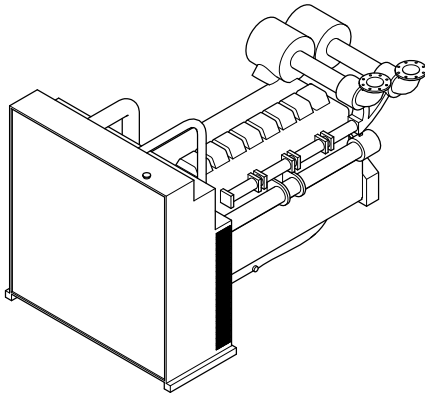

Engine Manufacturer/Brand.....	Perkins
Engine Model.....	4008-TAG2
Dimensions L×W×H.....	3711×2046×2146mm
Dry Weigh (approx.)	4320kg
Number of Cylinders.....	8
Bore.....	160mm
Stroke	190mm
Displacement.....	30L
Compression Ratio.....	13.6
Type of Injection	Direct injection
Intake System.....	Turbocharged
Intake Resistance.....	≤3.7kPa
Cooling System	Water cooled
Fan	Pusher
Battery Voltage	24V
Type of Fuel.....	BS2869 class A2 or BS EN590
Type of Oil	API 15W/40
Oil Capacity	153L
Type of Coolant	Glycol mixture
Coolant capacity.....	149L
Back Pressure	≤8.0kPa
Standby Power985kW
Prime Power899kW

Alternator

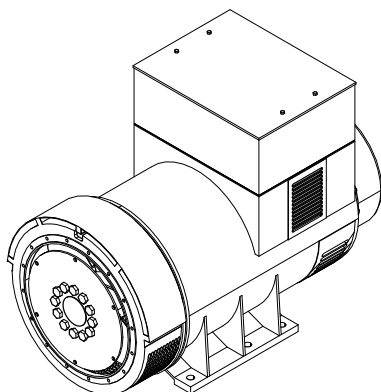

Alternator Manufacturer/Brand	LSA
Alternator Model	LSA49.3L10
Exciter.....	Brushless
Cooling Fan	Cast alloy aluminum
Windings.....	100% copper
Insulation Class	H
Winding Pitch.....	2/3
Terminals	6
Drip Proof	IP23
Altitude.....	≤1000m
Overspeed	2250 rpm
Air Flow.....	1.614m³/s(50HZ),1.961m³/s(60HZ)
Voltage Regulation	±0.5%
Total harmonic TGH / THCat no load < 1.5 % - on load < 5%	
Telephone Interference.....	THF<2%;TIF<50

ComAP MRS IL4 Control System

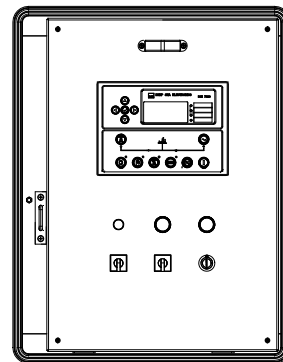

ComAp MRS16 IL4 is an advanced control module based on micro-processor, containing all necessary functions for protection of the genset and the breaker control. It can monitor the mains supply, and automatically start the engine when the mains is abnormal. Accurately measure various operational parameters and display all values and alarms information on the LCD. In addition, the control module can automatically shut down the engine and indicate the engine failure.

- Microprocessor control, with high stability and credibility
- Monitoring and measuring operational parameters of the mains supply and genset
- Indicating operation status, fault conditions, all parameters and alarms
- Multiple protections; multiple parameters display, like pressure, temp. etc.
- Manual, automatic and remote work mode selectable
- Real time clock for time and date display, overall runtime display, 250 log entries
- Overall power output display
- Integral speed/frequency detecting, telling status of start, rated operation, overspeed etc.
- Communication with PC via RS485 OR RS232 interface, using MODBUS protocol

4 Overall Dimensions

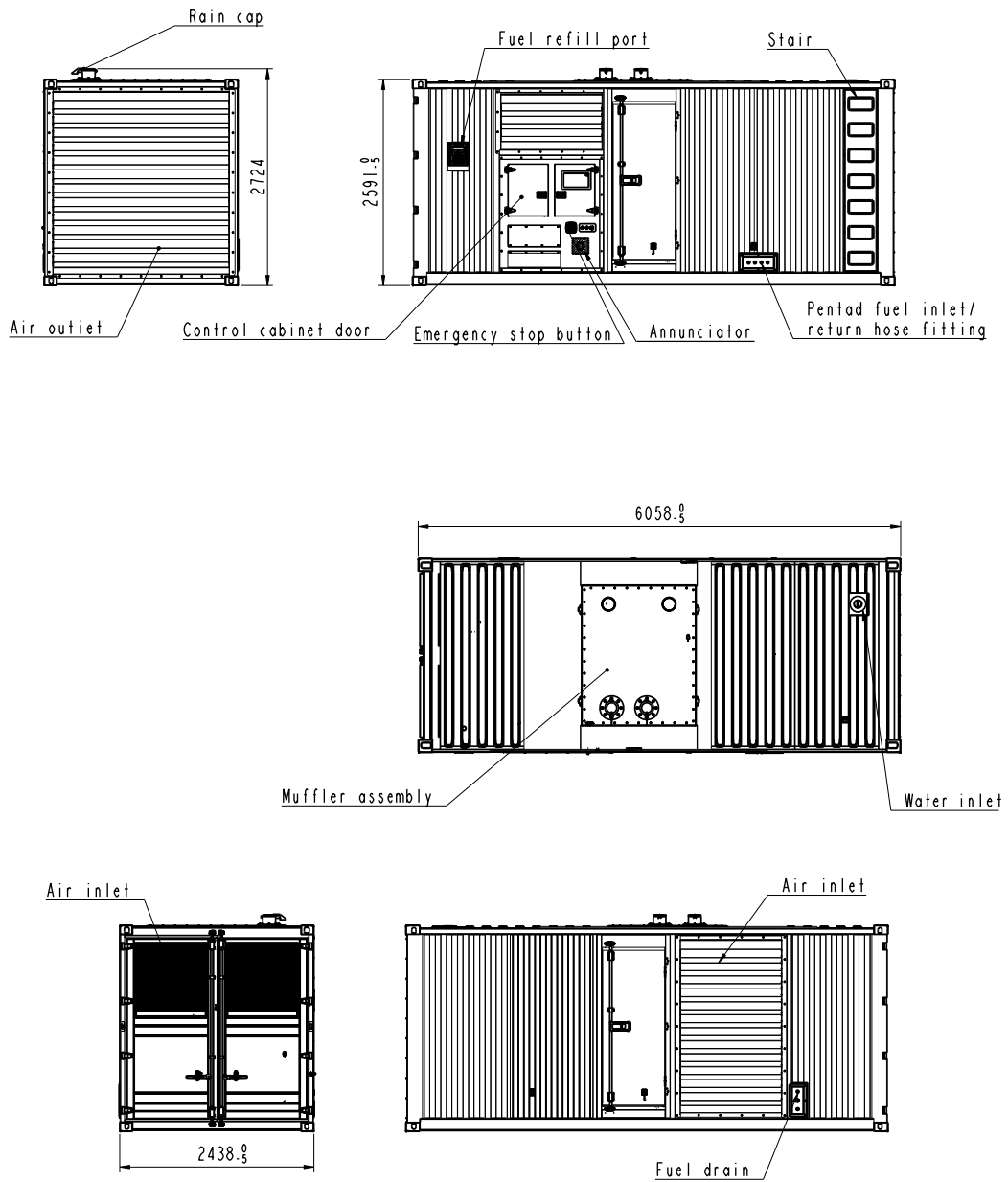

5 Control System

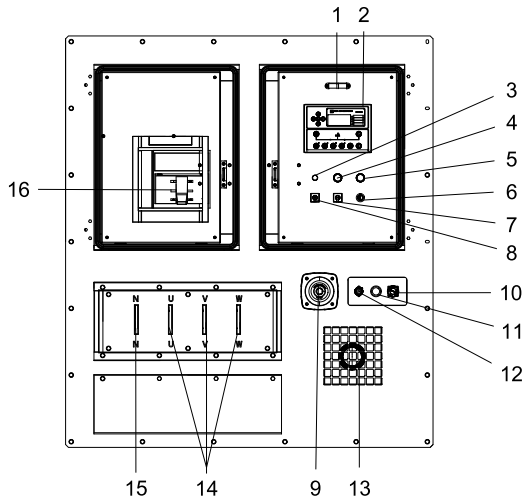

Control & field wiring cabinet

Ref.	Description
1	Control cabinet lamp
2	Control module
3	Charger indicator
4	Open genset indicator
5	Close genset indicator
6	Key switch
7	Control cabinet lamp switch
8	Control power switch
9	Emergency stop switch
10	9pin, Mains input/Remote control/ATS communication connector
11	Protective ring
12	4pin, Remote start
13	Sound and light annunciator
14	Live wire terminals
15	Neutral wire terminal
16	Main circuit breaker

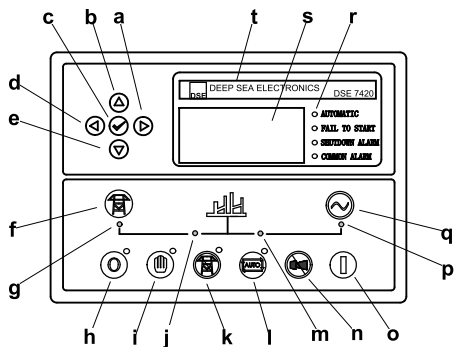

Control module

a	Button (next page)
b	Button (increase value / previous item)
c	Button (accept)
d	Button (previous page)
e	Button (decrease value / next item)
f	Button (transfer the load to the mains supply, when in Manual mode only)
g	Mains supply available LED
h	Stop / Reset button
i	Manual button (Manual control mode)
j	Mains supply on load LED
k	Test button (Test mode)
l	Auto button (Auto mode)
m	Genset on load LED
n	Mute/Lamp test button
o	Start button (Manual)
p	Genset available LED
q	Button (transfer the load to the genset, when in Manual mode only)
r	Alarm LED (4 alarm items)
s	LCD display
t	Control module name